

Operation Manual

INJECTION DEVICES

1K

Art.No.:

0644426

0644517

0660410

0669680

0669679

0669225

0669224

Type:

HD 1

HD 2

HD 3

HD 4

HD 5

Serial No.:

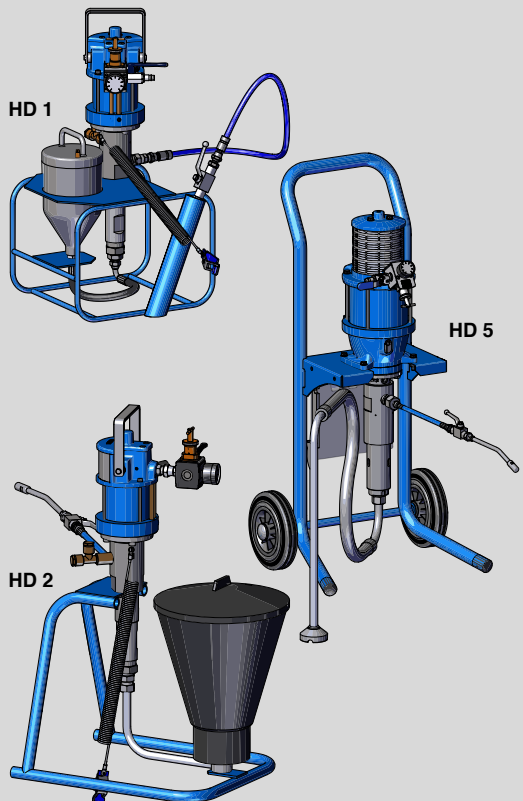

EU declaration of conformity



in accordance with ATEX Directive 2014 / 34 / EU and Annex II, No. 1 A of Machine Directive 2006 / 42 / EG

The company **WIWA Wilhelm Wagner GmbH & Co. KG**
35633 Lahnau
Gewerbestraße 1–3
Germany

hereby declares that the **INJECTION DEVICES**
machine type
with serial no.

conforms with aforementioned provisions.

The listed machine is assigned to Group II, Category 2G.

Labeling:  II 2G Ex h IIB T4 Gb

Responsible for documentation: **WIWA**, +49 (0)6441 609-0

Lahnau, December 18, 2025

Place, Date



Dipl.-Ing. (FH) Peter Turczak
Managing Director

Contents

1	Foreword	1
2	Safety	3
2.1	Explanation of symbols	3
2.2	Safety notes	6
2.2.1	Working pressure	7
2.2.2	Explosion protection	7
2.2.3	Health risks	9
2.3	Safety signs	10
2.4	Safety features	10
2.4.1	Safety valve	11
2.4.2	Compressed air shut-off valve	12
2.4.3	Ground cable	12
2.5	Operating and maintenance personnel	13
2.5.1	Obligations of the owner	13
2.5.2	Personnel qualifications	13
2.5.3	Authorized operator	14
2.5.4	Personal protective equipment	14
2.6	Warranty and liability	15
2.6.1	Spare parts	15
2.6.2	Accessories	16
2.7	How to respond in an emergency	16
2.7.1	Leakage	16
2.7.2	Injuries	17
3	Description	18
3.1	Intended use	24
3.2	Erroneous use	25
4	Transport, installation, and assembly	26
4.1	Transport	26
4.2	Installation site	27
4.3	Assembly	28
4.3.1	Installing the material hose and injection lance	29
4.3.2	Connecting the compressed air supply	30
4.3.3	Grounding the machine	31
5	Operation	32
5.1	Putting the machine into operation	32
5.1.1	Flushing out the remains of the test substance	33

5.1.2	Filling the machine with processing material and ventilating	33
5.2	General information	34
5.3	Injection	34
5.4	Flushing	36
5.5	Work interruption	37
6	Maintenance	39
6.1	Regular testing	40
6.2	Maintenance schedule	41
6.3	Safety valve	42
6.3.1	Checking the safety valve	42
6.3.2	Replacing the safety valve	43
6.4	Checking the compressed air and material hoses	44
6.5	Checking the release agent level	44
6.6	Checking the release agent for impurities	46
6.7	Recommended operating fluids	46
7	Remedying operational faults	47
8	Technical Information	50
8.1	Type plate	50
8.2	Machine card	50
8.3	QR code	51
8.4	Emission sound pressure level in the workplace	51

1 Foreword

Dear valued customer,

We are delighted that you have chosen one of our machines.

This operation manual is directed at the operating and maintenance personnel. It contains all information required in order to work with this machine.



The owner must ensure that the operating and maintenance personnel always have access to a copy of the operation manual in a language that they understand.

In addition to the operation manual, further information is also essential for the safe operation of the machine. Read and observe the directives and accident prevention regulations valid in your country.

In Germany, these are:

- ▶ DGVV rule 100-500, chap. 2.29 “Processing coating materials”,
- ▶ DGVV rule 100-500, chap. 2.36 “Working with fluid jets”,

both from the professional association for gas, district heating and water management.

We recommend enclosing all relevant directives and accident prevention regulations with the operation manual.

Furthermore, always observe the safety data sheets, manufacturer’s instructions and processing guidelines for coating or conveyance materials.

If questions should arise, we would be happy to assist you.

We wish you excellent working results with your machine

WIWA Wilhelm Wagner GmbH & Co. KG

Copyright

© 2025 WIWA

The copyright to this operation manual belongs to
WIWA Wilhelm Wagner GmbH & Co. KG
Gewerbestraße 1–3 • 35633 Lahnau • Germany
Phone: +49 (0)6441 609-0 • Fax: +49 (0)6441 609-2450
Email: info@wiwa.de • Website: www.wiwa.de

This operation manual is intended exclusively for the preparation, operating and maintenance personnel. It is expressly prohibited to distribute this operation manual, duplicate, exploit or communicate its contents, unless expressly authorized to do so. Infringement will lead to compensation. All rights to any patent, utility model or design registrations are reserved.

2 Safety

This machine has been designed and manufactured taking into consideration all safety aspects. It conforms to the current state of the art and the applicable accident prevention regulations. The machine left the factory in faultless condition and guarantees a high level of technical safety. However, improper operation and misuse will pose a risk to:

- ▶ the life and limb of the operator or third parties,
- ▶ the machine and other property of the owner,
- ▶ the efficient function of the machine.

It is fundamentally prohibited to implement any method of work that has a negative influence on the safety of the operating personnel and the machine. All persons involved in the installation, commissioning, operation, care, repair and maintenance of the machine must have read and understood the operation manual beforehand – in particular the “Safety” chapter.

Your safety depends on it!

We recommend that the machine owner have this confirmed in writing.

2.1 Explanation of symbols

Safety notes warn of potential accident risks and describe the measures required for accident prevention. In the **WIWA** operation manuals, safety notes are highlighted and labeled as follows:

DANGER

Signals a risk of accidents that are very likely to result in serious injuries and even death, if the safety note is not observed!

WARNING

Signals a risk of accidents that may result in serious injuries and even death, if the safety note is not observed!

CAUTION

Signals a risk of accidents that may result in injuries, if the safety note is not observed!



Signals important information for proper handling of the machine. A failure to observe this may result in damage to the machine or its environment.

Various pictograms are used in the safety notes for accident risks that may result in injury, depending on the hazard source.

Examples:



General risk of accident



Risk of explosion due to explosive atmosphere



Risk of explosion due to explosive substances



Risk of accident due to electricity or electrostatic charge



Warning of crushing



Warning of corrosive substances



Risk of injuries due to rotating machine parts



Risk of burning due to hot surfaces



Risk of freezing due to cold surfaces

The first line of the safety instructions indicates the personal protective equipment that must be worn. This is also highlighted and labeled as follows:



Wear protective clothing

Signals an instruction to wear the prescribed protective clothing, in order to prevent skin injuries due to the processing material or gases.



Use eye protection

Signals an instruction to wear protective goggles, in order to prevent eye injuries due to material spray, gases, vapors or dust.



Use ear defenders

Signals an instruction to wear ear defenders, in order to prevent damage to hearing caused by noise.



Use respiratory protection

Signals an instruction to use respiratory protection, in order to prevent damage to the respiratory tract caused by gases, vapors or dust.



Wear protective gloves

Signals an instruction to wear protective gloves in order to prevent injuries due to aggressive chemicals, burns when processing heated materials, or freezing due to contact with very cold surfaces.



Wear safety shoes

Signals an instruction to wear safety shoes, in order to prevent foot injuries due to falling, toppling or rolling objects, as well as slipping on slippery floors.



Signals references to directives, work instructions and operation manuals that contain very important information and must be observed.



Indicates a special note on explosion protection.



Indicates a special note on grounding.

2.2 Safety notes



WARNING

Always remember that this machine operates at high pressures and can cause life-threatening injuries if handled incorrectly!

Do not leave the machine unattended during operation. You must be able to intervene immediately in an emergency.

Do not insert tools or other objects into the ventilation openings of motors or pumps and make sure that no dirt gets inside, otherwise injuries and damage to the machine may occur.



Always observe and follow all information in this operation manual and in the separate operation manuals for the individual machine parts and optional accessories.

2.2.1 Working pressure



WARNING

Parts that are not designed for the maximum permissible working pressure may rupture and cause serious injuries.

- ▶ It is essential to observe the prescribed maximum working pressures for all parts. With varying working pressures, the lowest value always applies as the maximum working pressure for the complete machine.
- ▶ Material hoses and hose assemblies must comply with the maximum operating pressure including the required safety factor.
- ▶ Material hoses may not exhibit leakage, kinks, signs of wear or bulges.
- ▶ Hose assemblies must be tight.

2.2.2 Explosion protection

The following short designations are used in the instructions of **WIWA**:

- ▶ Ex protection: Explosion protection
- ▶ Ex area: potentially explosive or non-explosion protected area
- ▶ Non-Ex area: non-explosive or explosion protected area
- ▶ Ex zone: Explosion protection zone according to ATEX Directive
- ▶ ATEX knowledge: Knowledge of explosion protection according to ATEX Directive



Machines and accessories that are not explosion-protected may not be used in operating facilities that fall under the explosion protection ordinance!

Explosion-protected machines can be identified by the corresponding  mark on the type plate and/or the ATEX-declaration of conformity provided.

When using the machine in Ex zones, the specialist personnel must have knowledge of ATEX.

Explosion-protected machines meet the requirements of the ATEX Directive for the device group, device category and temperature class cited on the type plate or in the declaration of conformity.

The owner is responsible for designating the zoning in accordance with ATEX Directive, Appendix II, No. 2.1–2.3 in accordance with the stipulations of the responsible regulatory body. The owner is required to check and ensure that all technical data and labeling comply with the applicable stipulations according to ATEX.

For applications where a failure of the device could lead to dangers to personnel, the owner is required to implement appropriate safety measures.

Please note that some parts have their own type plate with separate labeling according to ATEX. In this case, the lowest explosion protection of all labels displayed applies to the entire machine.

If agitators, heaters or other electrically operated accessories are attached, the explosion protection must be checked. Plugs for heaters, agitators, etc. that do not have explosion protection may only be plugged in outside of areas that fall under the explosion protection ordinance, also if the accessory itself is explosion protected.

2.2.3 Health risks



CAUTION

Depending on the materials being processed, solvent vapors may arise, which could cause damage to health and property.

- ▶ Make sure the workplace is sufficiently ventilated and aired.
- ▶ Always observe the safety data sheets and processing instructions of the material manufacturer.



When handling paint, solvents, oils, greases, and other chemical substances, observe the safety and portioning instructions of the manufacturer and the generally applicable regulations.



Only use suitable skin protection, skin cleansing and skincare products for cleansing the skin.

In systems that are closed or under pressure, dangerous chemical reactions may arise, if parts produced from aluminum or galvanized parts come into contact with 1,1,1 - trichloroethane, methylene chloride or other solvents that contain halogenated chlorinated hydrocarbons (CFCs). If you wish to process materials that contain the aforementioned substances, we recommend that you contact the material manufacturer to clarify their suitability for use.

A range of machines in rust and acid-resistant designs is available for these types of materials.

2.3 Safety signs

The safety signs attached to the machine, such as the orange tag (see Fig. 1), indicate possible dangers and must be observed.

By scanning the QR code, the most important safety information for this machine can be accessed. Also read and observe the safety notes in the operation manual!

Additional symbols on the machine correspond to the labeling of the safety notes described in section 2.1 on page 3.

The safety signs may not be removed from the machine.

Damaged and illegible safety signs must be replaced immediately.



Fig. 1: Safety notes

2.4 Safety features



WARNING

If one of the safety features is missing or is not fully functional, the operating safety of the machine is not guaranteed!

- ▶ Put the machine out of operation immediately if you detect safety feature defects or any other faults on the machine.
- ▶ Only put the machine back into operation once the faults have been fully rectified.

The machine is equipped with the following safety features:

- ▶ Safety valve,
- ▶ Compressed air shut-off valve,

- ▶ Ground cable.

Check the safety features on the machine:

- ▶ Prior to commissioning,
- ▶ Always prior to starting work,
- ▶ After all set-up work,
- ▶ After all cleaning, maintenance, and repair work.

Checklist for checking the safety features

- Is the ground cable undamaged?
- Is the ground cable correctly connected, both to the device and to the conductor?
- Can the compressed air shut-off valve be actuated?

2.4.1 Safety valve

A safety valve is located on the air motor of the machine.

The safety valve prevents the maximum permissible air inlet pressure from being exceeded.

If the air inlet pressure exceeds the limit value setting, the safety valve discharges. (Functionality test see section 6.3.1 on page 42.)

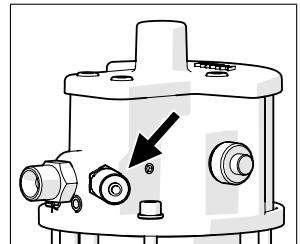

Fig. 2: Safety valve



WARNING

If the maximum permissible air inlet pressure is exceeded, parts may rupture. The consequences may be personal injuries and property damage.

- ▶ Operate the machine only with a functional safety valve!

2.4.2 Compressed air shut-off valve

The air supply of the machine can be interrupted with the compressed air shut-off valve.

The functional principle of all compressed air shut-off valves installed on the machine is the same:

- ▶ Open ⇒ Position ball valve in the flow direction
- ▶ Close ⇒ Position ball valve transverse to the flow direction

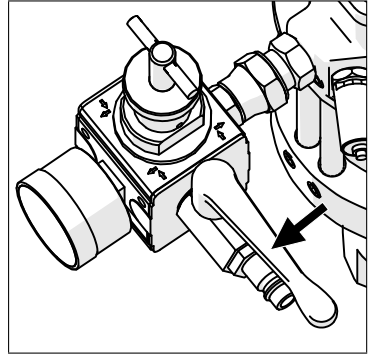

Fig. 3: Compressed air shut-off valve



After shutting off the air, the machine remains under pressure. It is therefore always necessary to fully relieve the pressure prior to any maintenance and repair work.

2.4.3 Ground cable

The ground cable serves to prevent electrostatic charging of the machine.

The ground cable is already connected to the machine at the time of delivery (e. g. to the high pressure filter, the frame, the grounding rail, or the like).

If the ground cable is lost or defective, replace it immediately (art. no. 0659675)!

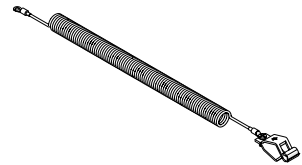

Fig. 4: Ground cable



The grounding points on this machine are labeled with the symbol shown on the left.

2.5 Operating and maintenance personnel

2.5.1 Obligations of the owner

The owner:

- ▶ is responsible for training the operating and maintenance personnel,
- ▶ must instruct the operating and maintenance personnel on correct handling of the machine, and on wearing the correct work clothing and protective equipment,
- ▶ must make work aids, such as e. g. lifting gear for transporting the machine or container, available to the operating and maintenance personnel,
- ▶ must make the user manual accessible to the operating and maintenance personnel and must ensure that it remains constantly available,
- ▶ must ensure that the operating and maintenance personnel have read and understood the user manual.

Only then are they permitted to put the machine into operation.

2.5.2 Personnel qualifications

Differentiation is made between two groups of personnel, depending on their qualifications:

- ▶ **Instructed operators** have received verified instruction from the machine owner regarding the tasks entrusted to him and the possible risks if the correct procedure is not followed.
- ▶ **Trained personnel** have received instruction provided by the machine manufacturer and are capable of carrying out maintenance and repair work on the machine, independently recognizing possible dangers and avoiding risks.

2.5.3 Authorized operator

Activity	Qualification
Set-up and operation	Instructed operator
Cleaning	Instructed operator
Maintenance	Trained personnel
Repair	Trained personnel



Children, young persons under the age of 16 and untrained personnel may not operate this machine.

2.5.4 Personal protective equipment



Wear protective clothing

Always wear the protective clothing stipulated for your working environment (e.g. anti-static protective clothing in potentially explosive areas) and also observe the recommendations in the safety data sheet of the material manufacturer.



Use Eye Protection

Wear protective goggles in order to prevent eye injuries due to material spray, gases, vapors or dust.



Use Ear Defenders

Suitable noise protection equipment must be made available to the operating personnel. The machine owner is responsible for compliance with the accident prevention regulation "Noise" (BGV B3). It is therefore necessary to pay particular attention to the conditions at the installation site – for example, noise pollution can increase if the machine is installed in or on hollow bodies.

**Use respiratory protection**

Although the airless and AirCombi spray processes minimize the paint mist with the right pressure adjustment and correct work method, we recommend that you use a respiratory protection mask.

**Wear Protective Gloves**

Wear anti-static, chemical-resistant protective gloves with forearm protection to prevent injuries due to aggressive chemicals, burns when processing heated materials, or freezing due to contact with very cold surfaces.

**Wear Safety Shoes**

Wear anti-static safety shoes, in order to prevent foot injuries due to falling, toppling or rolling objects, as well as slipping on slippery floors.

2.6 Warranty and liability

Except when otherwise stipulated,

- ▶ our General Terms and Conditions (GTC) apply for deliveries within Germany,
- ▶ our Orgalime SI 14 apply for deliveries to all other countries.

2.6.1 Spare parts

- ▶ When repairing and maintaining the machine, original spare parts from **WIWA** must be used.
- ▶ If spare parts are used that have not been produced or supplied by **WIWA**, the warranty is void and all liability shall be excluded.

2.6.2 Accessories

- ▶ If you use original **WIWA** accessories, their suitability for use in our machines is guaranteed.
- ▶ If you use third-party accessories, these must be suitable for the machine – in particular with respect to the working pressure, the current connection data, the connection variables, and use in Ex-zones, if applicable. **WIWA** will not be liable for any damage or injuries due to these parts.
- ▶ It is essential to observe the safety provisions applicable to the accessories. You can find these safety provisions in the separate operation manuals for the accessories.

2.7 How to respond in an emergency

2.7.1 Leakage



WARNING

In case of leakage, material may escape under very high pressure and cause serious physical injuries and property damage.

- ▶ Stop the machine immediately and relieve the pressure.
- ▶ Tighten threaded connections and replace defective parts (must be performed by trained personnel).
- ▶ Do not seal leakage at connections and on high pressure hoses with the hand or by wrapping.
- ▶ Do not patch material / high pressure hoses!
- ▶ Check hoses and threaded connections for leak-tightness before starting the machine up again.

2.7.2 Injuries

In case of injuries caused by processing material or cleaning agents, always have the safety data sheet ready to show to the doctor (supplier or manufacturer address, their telephone number, material designation and material number).

3 Description

The **INJECTION DEVICES** are pneumatically operated, one-component high pressure injection systems.

Areas of application are e. g.

- ▶ Concrete and structural renovation
- ▶ Fire protection
- ▶ Mining (only in the model for Atex zone 1)

The technical data for your machine can be found in section 8 on page 50, on the enclosed machine card or on the type plate.

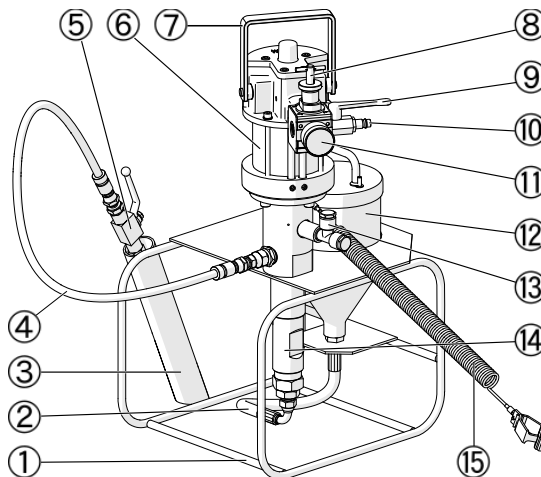

Fig. 5: HD 1

No.	Description
1	Frame
2	Suction hose/line
3	Retaining tube for injection lance
4	Material hose
5	Injection lance

No.	Description
6	Air motor
7	Carrying handle
8	Compressed air regulator
9	Compressed air shut-off valve
10	Air inlet
11	Pressure gauge
12	Material drum
13	Filler neck/opening for release agent
14	Fluid pump
15	Ground cable
16	Button for opening the bottom valve (only HD 3)

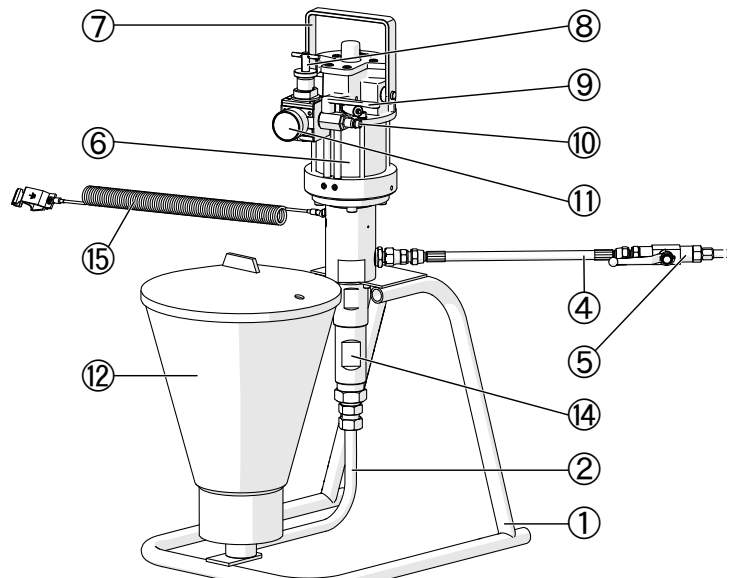

Fig. 6: HD 2

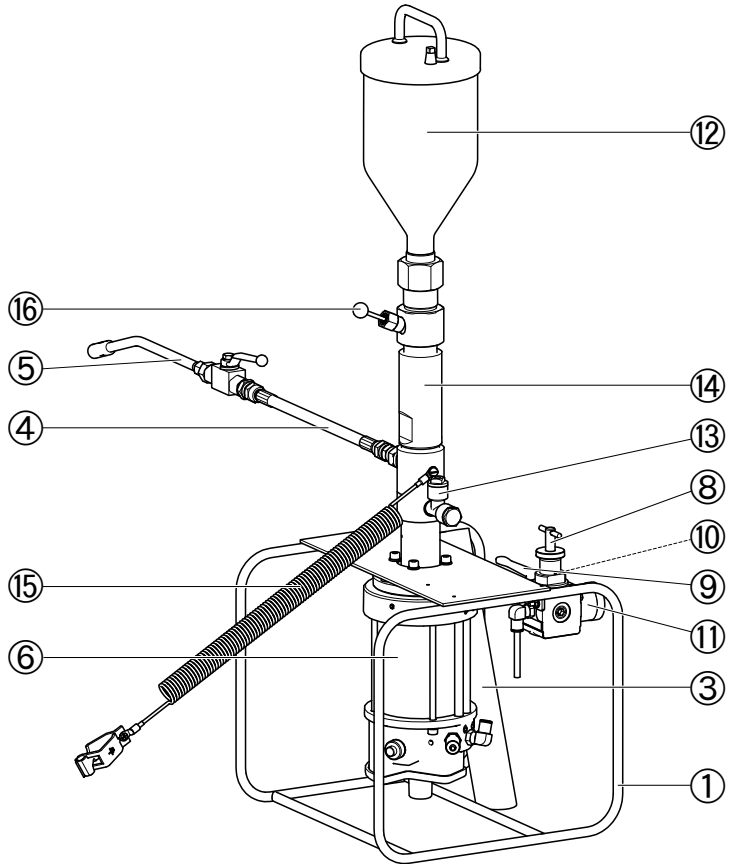
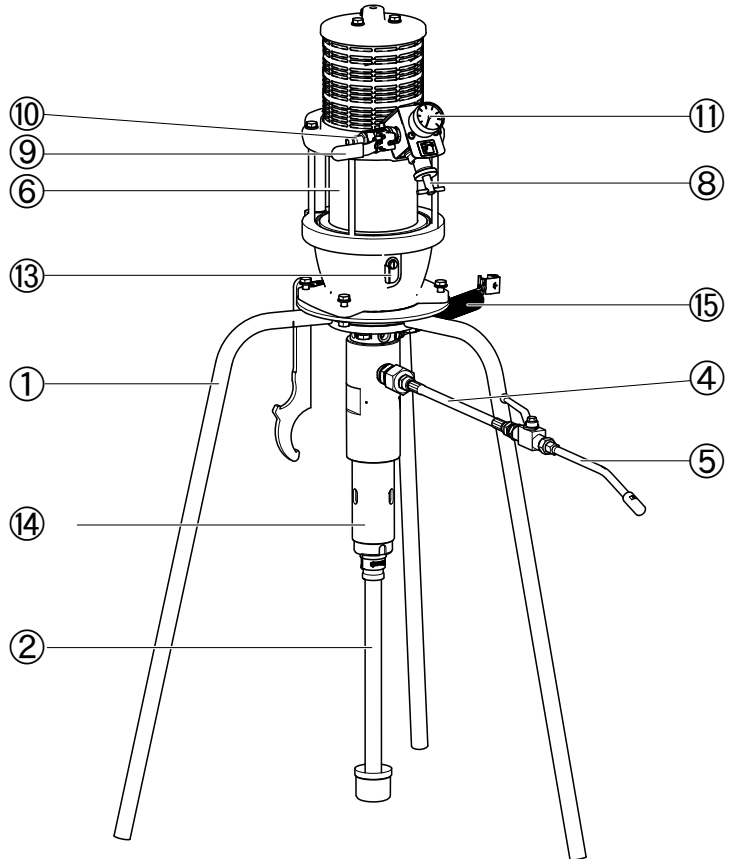

Fig. 7: HD 3

**Fig. 8:** HD 4

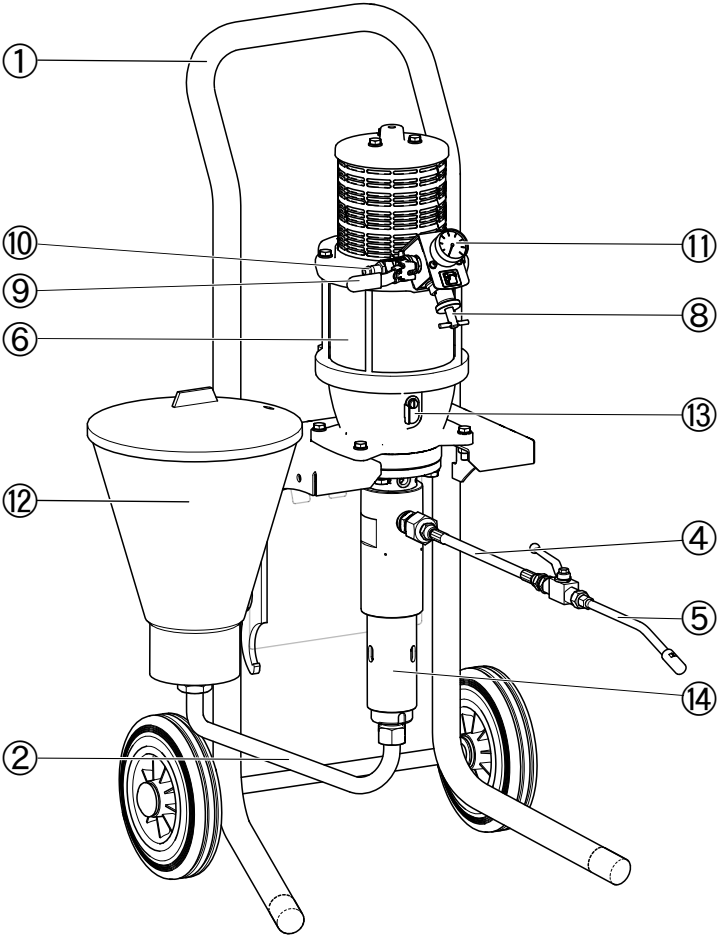

Fig. 9: HD 5 (model with hopper)

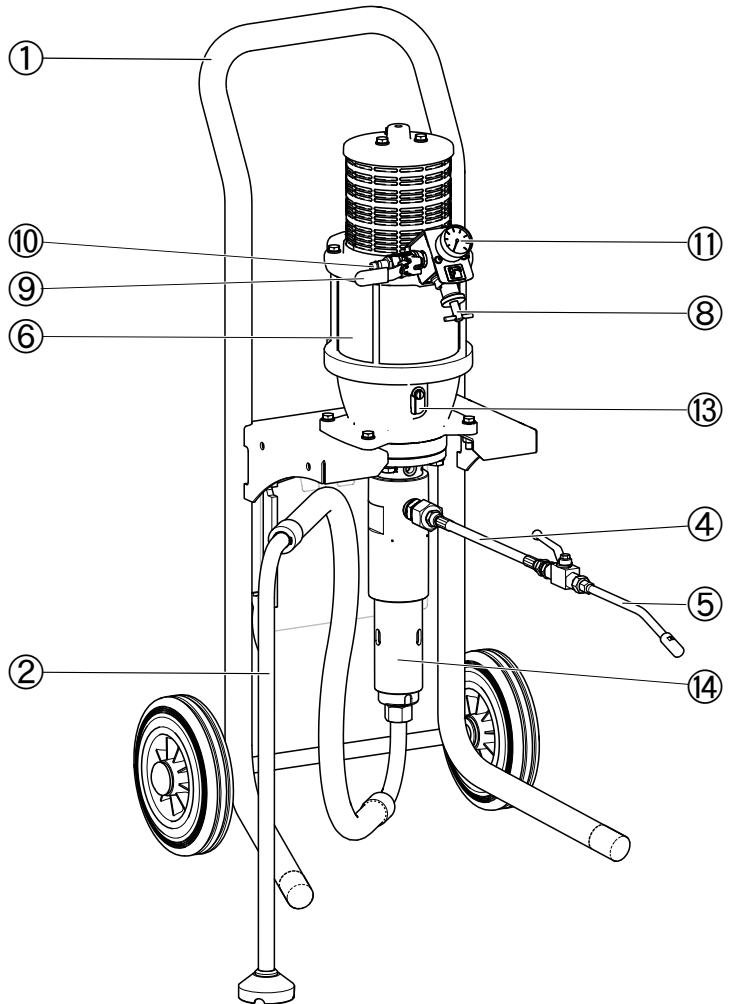

Fig. 10: HD 5 (model with suction hose)

There are specially protected versions of HD 2 and HD 5 for use in mining (Atex zone 1):

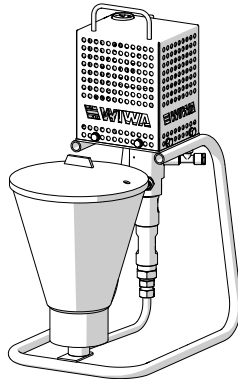

Fig. 11: HD 2 mining

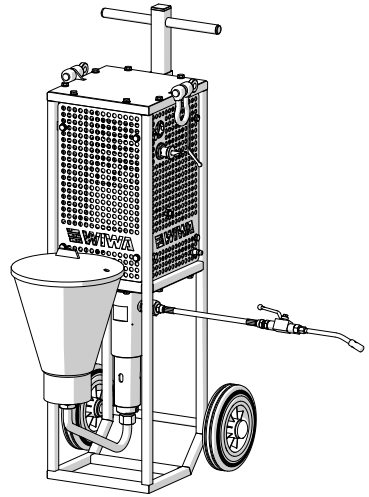

Fig. 12: HD 5 mining

3.1 Intended use

The **WIWA** injection units are one-component high pressure systems with pneumatic drives designed according to the requirements of ZTV-ING. They are suitable for processing low-viscosity injection resins based on epoxies or polyurethanes, as well as sealing gels.

The machine is easily transportable, ideal for work on a scaffold or in a shaft.



Intended use also includes:

- ▶ observing the technical documentation and
- ▶ complying with the operating, maintenance and servicing guidelines.

3.2 Erroneous use

Any use other than that stipulated in the technical documentation is deemed to be erroneous use and will void the warranty.

Erroneous use applies in particular if

- ▶ impermissible materials are processed,
- ▶ unauthorized modifications or changes are implemented,
- ▶ the safety features are removed, modified or bypassed,
- ▶ spare parts are installed that were not manufactured or delivered by **WIWA** (see section 2.6.1 on page 15),
- ▶ accessories are used that are not suitable for the machine (see section 2.6.2 on page 16),
- ▶ machines without  identification are used in potentially explosive atmospheres,
- ▶ the machine is operated outside of the operating limits according to the type plate.

4 Transport, installation, and assembly



The machine left the factory in faultless condition, packaged correctly for transport.

Check the machine at the time of receipt for any transport damage and for completeness.

4.1 Transport

When transporting the machine, observe the following information:

- ▶ A handle is located on the top of the air motor for carrying the machine (only HD 1 & 2).
- ▶ When loading the machine, ensure sufficient load-bearing capacity of the lifting gear and lifting accessories. The dimensions and weight of the machine can be found on the machine card and type plate.
- ▶ Attention: danger of tipping! Ensure the load is evenly distributed, in order to prevent the machine from tipping.
- ▶ When lifting or loading the machine, do not transport other objects simultaneously (e. g. material drums) with the machine.
- ▶ Never stand under suspended loads or in the loading area. There is a risk of death here!
- ▶ Secure the load on the transport vehicle to prevent sliding and falling.

If the machine has previously been in operation, please observe the following:

- ▶ Disconnect the entire energy supply to the machine - even for short transport distances.
- ▶ Empty the machine prior to transport - residual liquids may still leak out of the machine during transport.

- Remove all loose parts (e.g. tools) from the machine.

4.2 Installation site

Ambient temperature:

- minimum: 0 °C or 32 °F
- maximum: 40 °C or 104 °F



WARNING

If the machine is used outdoors during a storm, a life-endangering situation may arise for the operating personnel due to lightning!

- Never operate a machine outdoors during a storm!
- The owner must ensure that the machine is equipped with suitable lightning protection equipment.

Safety measures at the installation site:

- Position the device horizontally on ground that is level, firm and free of vibrations. The device may not be tilted or tipped.
- Make sure that all controls and safety features are easy to reach.
- Keep the working area clean, especially all walking and standing areas. Remove any spilled cleaning fluid or injection materials immediately.
- Always observe and follow the safety data sheets and processing instructions of the material manufacturer.
- Ensure that the working area has sufficient airing and venting to prevent damage to health and property.
- Although there are no legal regulations for the low-mist injection process itself, dangerous solvent vapors and material particles must be extracted.
- Protect all items neighboring the object against possible damage due to material spray.

4.3 Assembly

**WARNING**

If untrained personnel carry out assembly work, they endanger themselves and others, and risk the operational safety of the machine.

**WARNING**

During assembly work, ignition sources may arise (e. g. due to mechanical sparks, electrostatic discharge, etc.).

- ▶ Carry out all assembly work outside of potentially explosive areas.

**WARNING**

Parts that are not designed for the maximum permissible working pressure of the machine may rupture and cause serious injuries.

- ▶ Prior to installing accessories, make sure that these are designed for the maximum working pressure of the machine.

Before the assembly work, ensure that:

- the compressed air shut-off valve is closed,
 - the compressed air regulator is completely turned down and
 - the material shut-off valve (if present) is closed.
- ▶ Prior to commissioning, correctly refit any parts or equipment removed for transport purposes, as required for the intended use.

4.3.1 Installing the material hose and injection lance



WARNING

If the connections for the hoses are subjected to strain, these may be torn out. The material escaping under high pressure may cause injuries and damage to property.

- ▶ If tensile forces are anticipated on the hose connections (for example due to the positioning of the mixing unit), it is necessary to utilize strain relief!

No.	Description
1	Material outlet on the high pressure pump
2	Material hose
3	Material inlet on the injection lance
4	Connection for coupling piece and packer

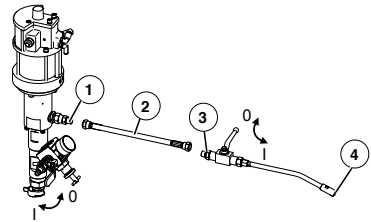

Fig. 13: Connecting the material hose and injection lance

1. Connect the material hose to the material outlet of the fluid pump,
2. Install the other hose end to the injection lance,



The coupling piece and packer are not part of the scope of delivery of the machine. The selection of the coupling piece is dependent on the type of packer used.

The following coupling pieces are optionally available from WIWA:

No.	Coupling piece
1	Coupling G $\frac{1}{4}$ " I
2	Nozzle M10×1 IG
3	Slide coupling M10×1

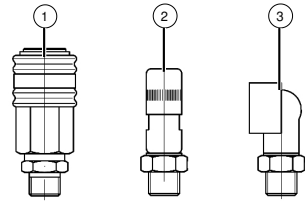

Fig. 14: Coupling pieces for the packer

4.3.2 Connecting the compressed air supply



CAUTION

Lines laid on walking surfaces are a tripping hazard capable of causing injuries to the operating personnel.

- ▶ Place the compressed air line so that a tripping hazard for the operating personnel cannot result.



To ensure the required quantity of air, the compressor output must comply with the air requirement of the machine, and the diameter of the air supply hoses must match the connections.



Operation with contaminated or moist compressed air leads to damage in the machine's pneumatic system.

- ▶ Use only dried, oil-free and dust-free compressed air, which corresponds to purity class [7:5:4] according to ISO 8573-1:2010!

1. Make sure that all compressed air shut-off valves are closed and all compressed air regulators are turned all the way down.
2. Connect the compressed air line to the compressed air connection of the compressed air regulator or the air supply.

4.3.3 Grounding the machine

**WARNING**

The high flow velocities during operation can result in an electrostatic charge. Static discharges can result in fire and explosions.

- ▶ Ensure that the machine is properly grounded outside of Ex zones!

The ground cable is already connected to the machine at the time of delivery. Connect the terminal of the ground cable to an electrically conductive object outside of potentially explosive areas.

5 Operation

Prerequisites:

- ▶ The machine must be correctly installed and fully assembled.
- ▶ Only put the machine into operation if you are equipped with the prescribed personal protective equipment. Details on this can be found in section 2.5.4 on page 14.
- ▶ The injection material must be available in sufficient quantity.

Multiple collecting vessels are also required for surplus material. These containers are not included in the scope of delivery.



Observe and follow the material and safety data sheets of the respective material manufacturer when processing and storing acrylate gels and silicate injectors.



WARNING

If fluid pumps run dry, this can lead to fire or an explosion due to the resulting friction heat.

- ▶ During operation ensure that the drums never run empty. Never leave the machine running when unattended.
- ▶ However, if this were to happen, bring the respective pump to an immediate standstill and add material.

5.1 Putting the machine into operation

Checklist prior to commissioning:

- Are all safety features present and fully functional (see section 2.4 on page 10)?
- Are the machine and the object to be processed (if possible) correctly grounded (see section 4.3.3 on page 31)?
- Check the release agent level in the high pressure pump and top it off if necessary (see section 6.5 on page 44).

Overview of the work steps during commissioning:

1. Flush the machine (see section 5.4 on page 36) in order to flush out the factory-made test substance (during initial commissioning) or the remains of the previous injection material. Use the flushing agent recommended by the manufacturer of your injection material.
2. During flushing, check that all machine parts are leak-tight and tighten the connections if necessary.
3. Fill the machine with processing material and ventilate it.

5.1.1 Flushing out the remains of the test substance

Following assembly, the machine was tested in the factory for faultless function with a test substance. During initial commissioning, it is therefore necessary to first completely clean the machine to flush out the remaining test substance (section 5.4 on page 36).



Use the flushing agent recommended by the manufacturer of your processing material.

5.1.2 Filling the machine with processing material and ventilating

During this process, the processing material is pumped out of the material drum by the high pressure pump into a material collecting vessel until it escapes clean and free of bubbles. This pushes out the air that is in the entire system.

1. Fill the processing material into the material drum or place the suction hose into the material drum.
2. Hold the injection lance, directing the material ejection against the inner wall of the collecting vessel.
3. Open the compressed air shut-off valve on the compressed air regulator.
4. Let the high pressure pump start up slowly. Slowly adjust the air inlet pressure to approx. 1–2 bar for this.

5. Open the ball valve for the injection lance. Convey the material mixture in the machine into a collecting vessel until clean material escapes free of bubbles.
6. Turn the compressed air regulator down completely.
7. Close the compressed air shut-off valve.
8. Close the ball valve for the injection lance.

5.2 General information

- ▶ Observe the processing instructions of the material manufacturer. All materials to be processed are to be supplied by the manufacturer with information regarding viscosity, application temperatures, mixing ratios, etc. If this is not the case, please request this data from the respective manufacturer.
- ▶ **WIWA** offers a comprehensive range of accessories for the optimum preparation of materials, such as:
 - Agitators of various sizes
 - Material preheating drums of various sizes
 - Material fluid heater

5.3 Injection

Prerequisites:

- ▶ The machine has been put into operation.
 - ▶ The required packers are attached at the injection site.
1. Turn the compressed air regulator for the high pressure pump down completely.
 2. Close the ball valve on the injection lance.
 3. Connect the nozzle of the injection lance to the packer nipple.
 4. Open the ball valve on the injection lance.

5. Set a low air inlet pressure on the compressed air regulator for the high pressure pump. The injection material is now pressed into the injection site.
 - ▶ Start the injection with an as low of a pressure as possible so that the safety of operating personnel and the wall are not endangered.
 - ▶ Slowly increase the pressure to the desired working pressure.
6. After pressure equalization between the wall and the injection pump, the pump stops automatically.
7. Now increase the pressure as recommended by the material manufacturer. After the pressure is equalized again, the pump stops again. The injection site is filled completely.
8. Turn the compressed air regulator down completely.
9. Close the ball valve for the injection lance.
10. Switch to the next packer within the pot life of the material used and repeat the previous work steps of this chapter.



Always observe the pot life of the material used!

11. After completing the last injection process, immediately flush until clean cleaning agent runs out. Always observe the pot life of the material used!



We recommend flushing between the individual press units during the injection work, depending on the material and injection quantity, see section 5.4 on page 36.



Observe the fill level in the material drum during injection. Refilling the material in a timely manner prevents the pumps from suctioning air and thereby having to ventilate.

Note for setting the injection pressure

Operate the machine with only as much air pressure as is necessary. Observe the information of the material manufacturer. To be able to determine the actual injection pressure, multiply the existing air inlet pressure by the theoretical pressure ratio of the high pressure pump.

5.4 Flushing

Flushing the machine is necessary

- ▶ during initial commissioning so that the injection material is not influenced by the test substance with which the machine was tested for fault-free functioning in the factory.
- ▶ when material is changed.
- ▶ when work is interrupted and when decommissioning in order to flush injection material out of the machine during an interruption of operation before it hardens.



Observe the pot life of the materials used.

You will need:

- ▶ at least 5 l of cleaning agent, that is suitable for the material to be processed and is recommended by the material manufacturer, in an open container
- ▶ an additional electrically conductive collecting vessel for the cleaning agent that is flushed out

These containers are not included in the scope of delivery.

1. The compressed air shut-off valve must be closed.
2. Connect the material hose to the injection lance.
3. Connect the material hose with injection lance to the material outlet of the fluid pump.

4. Turn down the compressed air regulator by turning the adjusting screw to the left until it moves easily.
5. Connect the air inlet of the compressed air regulator for the unit to the compressed air network.
6. Fill the cleaning agent (container A) into the material drum of the device.
7. Open the compressed air shut-off valve.
8. Adjust the compressed air regulator to a max. of 2 bar by slowly turning the adjusting screw to the right.
9. Hold the injection lance in the open container B and spray laterally against the inner wall for at least 10 seconds. With metal containers, make sure that the injection lance is in continuous contact with the container wall due to a possible electrostatic charge.



For a good cleaning, we recommend a flushing time of about one minute.



WARNING

Heating cleaning agents can lead to an explosion. Serious personal injuries and property damage may result.

- ▶ Do not pump the cleaning agent for longer than 5 min!

5.5 Work interruption

1. Turn the compressed air supply for the high pressure pump down completely.
2. Close the ball valve on the injection lance.
3. Remove the injection lance from the packer nipple if necessary.



The duration of the work interruption may not exceed the pot life specified by the material manufacturer. If the period of work interruption is longer than the specified pot life, perform the complete cleaning according to section 5.4 on page 36.

6 Maintenance



Only perform maintenance on the machine if you are equipped with the prescribed personal protective equipment. Details on this can be found in section 2.5.4 on page 14.



WARNING

If untrained personnel carry out maintenance and repair work, they endanger themselves and others, and risk the operational safety of the machine.

- ▶ Maintenance and repair work on electrical parts may only be performed by specialist personnel with electrical qualifications — all other maintenance and repair work may only be done by **WIWA** customer service or specially trained personnel.



WARNING

During maintenance work, ignition sources may arise (e. g. due to mechanical sparks, electrostatic discharge, etc.).

- ▶ Carry out all maintenance work outside of potentially explosive areas.



When using the machine in Ex zones, the specialist personnel must have knowledge of ATEX.



Observe the maintenance information in the operation manual for the optional accessories.

Prior to maintenance and repair work:

1. Pump the processing material completely out of the material drum.

2. Shut off the compressed air supply,
3. Disconnect the power supply (if present),
4. Relieve the pressure in the machine completely.

**WARNING**

If parts of the machine are blocked (e.g. spray nozzle, material filter for the spray gun, material hose, high pressure filter, suction screen, etc.), it is not possible to fully relieve the pressure. During disassembly work, residual pressure may escape and cause serious injuries.

- ▶ Protect yourself against suddenly ejecting material by covering threaded connections with a cloth while loosening them.
- ▶ Loosen threaded connections particularly cautiously and allow the pressure to escape slowly.
- ▶ Eliminate the blockages (see fault table in section 7 on page 47).

After completion of the maintenance and repair work:

- ▶ Check the function of all safety features and the faultless function of the machine.

6.1 Regular testing

The machine must be inspected and maintained regularly by a specialist:

- ▶ prior to first commissioning,
- ▶ after changes to / the servicing of parts of the installation that affect safety,
- ▶ after an interruption to operation lasting more than 6 months,
- ▶ although at least every 12 months.

In the case of machines that have been put out of use, the test can be delayed until the next time commissioning takes place.

The results of the tests must be recorded in writing and stored until the next test. The test certificate or a copy of this must be available at the machine's place of use.



Have repair work carried out exclusively by **WIWA** Service or trained specialist personnel (in/from authorized workshops if necessary).



When using the machine in Ex zones, the specialist personnel must have knowledge of ATEX.

6.2 Maintenance schedule



The information in the maintenance schedule constitutes recommendations only. The time frames may vary depending on the characteristics of the materials used, as well as external influences.

Time frame	Activity	for further reading
Prior to each commissioning	Check release agent level in the fluid pump	section 6.5 on page 44
Once per week	Visual inspection of the compressed air and material hoses	
Every 50 operating hours	Check the release agent in the fluid pump for material residues	section 6.6 on page 46
Every 3 years	Inspection of the compressed air and material hoses by a specialist and replacement if necessary	

Time frame	Activity	for further reading
Every 6 years at the latest (incl. storage duration of the hose line)	Complete replacement of the compressed air and material hoses	section 6.4 on page 44

6.3 Safety valve

6.3.1 Checking the safety valve



Only perform the function test with a filled pump!

Depending on the size of the pump used and the required working pressure, safety valves with a 1/4" or 1/2" connection are used.

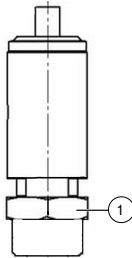

Fig. 15: 1/4" connection safety valve

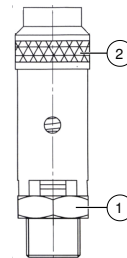

Fig. 16: 1/2" connection safety valve

No.	Description
1	Hexagon nut
2	Knurled nut

This is how to check the function of the safety valve:

Safety valves with a 1/4" connection:

1. Increase the air inlet pressure on the completely filled machine briefly to approx. 10% over the maximum permissible pressure according to the type plate. The safety valve must discharge!

Safety valves with a 1/2" connection:

Only perform the test by hand. To prevent damage to the safety valve, do not use any tools to release the knurled nut.

1. Reduce the air inlet pressure on the completely filled machine to approx. 10% below the maximum permissible pressure according to the type plate.
2. Open the safety valve for a few seconds by turning the knurled nut (Fig. 16 on page 42) counterclockwise. During this process, the closure of the safety valve opens, whereby the air must escape.
3. After this check, retighten the knurled nut clockwise.

6.3.2 Replacing the safety valve

Before replacing the safety valve, observe the following:

- ▶ the machine must be switched off and relieved of pressure,
- ▶ the data noted on the new valve must correspond to the data specified on the machine card. The calibration pressure specified on the safety valve may not be higher than the permissible working pressure of the machine,
- ▶ the new safety valve may not have any damage.

1. Attach an open end spanner to the spanner flat (Fig. 15 on page 42 and Fig. 16 on page 42) and unscrew the safety valve by turning counter-clockwise.
2. Check the connection point. It must be free of blockages and clean.

3. Insert a new safety valve and screw it tight clockwise with the open end spanner. The maximum torque is 30 Nm for a 1/4" connection and 40 Nm for a 1/2" connection.

6.4 Checking the compressed air and material hoses

Check the compressed air and material hoses weekly for externally visible damage, such as kinks, cracks, signs of wear or bulges.



Improper use and impermissible stress are the most frequent causes of damage. Damaged hoses must be replaced immediately.

Hose lines are subject to a natural aging even with proper use and permissible stress. Their duration of use is thereby limited. Therefore, the compressed air and material hoses must be checked by a specialist every three years.



The duration of use of a hose line, including any possible storage duration, may not exceed six years. The manufacturing date of a hose line (month/year) is stamped on the ferrule.

6.5 Checking the release agent level

The release agent cup for the pumps must be filled with release agent to keep the wear of the packings as low as possible.

Before each commissioning, check the release agent level and refill the release agent if necessary.

HD 1–3

Unscrew the sealing plug from the filler neck (Fig. 17).

At the optimal fill level, the release agent is visible in the filler neck (approx. 1 cm below the filler opening).

The total filling quantity is approx. 50 ml.

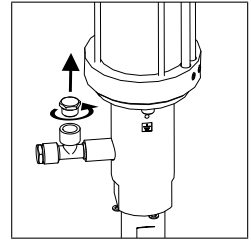

Fig. 17: Filling the release agent for HD 1–3

HD 4/5

The release agent should be at the center of the inspection glass (2) for optimal filling.

To fill the release agent, slide the cover for the filler opening (1) to the side and press the release agent in by means of a dosing bottle.

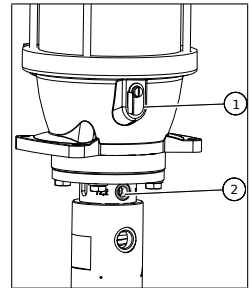

Fig. 18: Release agent openings for HD 4/5

6.6 Checking the release agent for impurities

Check the release agent regularly for impurities through flushing agent. To do so, drain a small quantity of release agent at the draining screw (Fig. 19).

If impurities are apparent in the release agent, you must assume that the packing for the flush pump is worn.

In this case, have the pump packing replaced as quickly as possible.

After performing the check, add a corresponding quantity of clean release agent through the filler opening. We recommend using the release agent from **WIWA** (order no. 0163333).

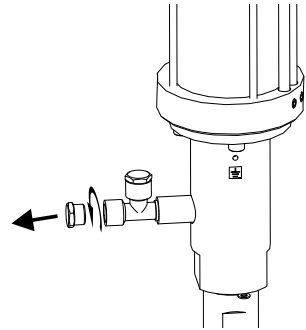

Fig. 19: Draining the release agent

6.7 Recommended operating fluids

Only use original operating fluids from **WIWA**:

Operating fluid	WIWA order number
Release agent, yellow, standard (0.5 l) ¹	0163333
Release agent, red, for isocyanate (0.5 l) ¹	0640651
Anti-freeze agent (0.5 l) ²	0631387
Pneumatic oil (0.5 l) ²	0632579

¹ Plasticizer for filling the release agent vessels of e. g. the proportioning pump, feed pump and flush pump as well as the dosing valves

² for the maintenance unit

The release agent and pneumatic oil are also available in larger containers on request.

7 Remediating operational faults



Only eliminate operational faults if you are equipped with the prescribed personal protective equipment. Details on this can be found in section 2.5.4 on page 14.

fault	possible cause	remedy
Pump does not start despite operation of the injection lance.	No compressed air present.	Check compressed air connection.
	Compressed air shut-off valve closed.	Open the compressed air shut-off valve.
	Air motor defective.	Repair air motor using the spare parts list and repair manual, contact WIWA customer service if necessary.
	Bottom valve is stuck (for HD 3).	Release the valve ball with the button.
	Suction hose or bottom valve clogged.	Unscrew the bottom valve and clean the ball and the seat thoroughly.

fault	possible cause	remedy
Pump is running, but no injection material is being conveyed to the outlet of the injection lance.	Suction hose blocked.	Replace hose.
	Ball in the bottom valve is stuck (does not lift).	<ul style="list-style-type: none"> ▶ Release the valve ball with the button (for HD 3). ▶ Open ball valve on the injection lance. ▶ Move the bottom valve to the side with a slight impact (hammer). ▶ Unscrew suction system and press out the ball in the bottom valve from the bottom using a pin or a screwdriver.
Pump conveys material, but does not stop when the injection lance is closed.	Bottom valve does not close.	Unscrew the bottom valve and clean the ball and the seat thoroughly.
	Packing or valve worn out.	Replace parts.

fault	possible cause	remedy
Pump runs smoothly, but the required injection pressure is not achieved.	The air pressure is too low.	Increase the air pressure at the compressed air regulator.
	Too little air.	Check the air line for the correct cross-section.
	Air motor ices up.	Reduce the air inlet pressure if possible. If not present, attach maintenance unit with oiler. Fill the oiler with anti-freeze agent (Glysantin) and set according to the instructions in the operation manual: The guideline is one drop for approx. 10 double strokes.
Pump runs irregularly.	The viscosity of the injection material is too high (loss of suction).	<ul style="list-style-type: none"> ▶ Dilute injection material ▶ Use a larger pump.
	Suction system is leaking (fluctuations in spray jet).	Check or replace the gaskets on all threaded connections of the suction pipe.
	Bottom valve is leaking (pump only stops in the upstroke when injection lance is closed).	Unscrew the bottom valve and clean the ball and the seat thoroughly, if necessary replace the ball or the valve seat.
	Piston valve is leaking (pump only stops in the downstroke when injection lance is closed).	Clean and check the ball and seat in the double piston, replace the ball or valve seat if necessary.
	Lower or upper packing leaks (wear).	Replace the packing.

8 Technical Information

8.1 Type plate

The type plate is located on the frame of the machine and contains the most important technical data:

- Manufacturer's address,
- Atex marking,
- Device type,
- Output per double stroke,
- Transmission ratio,
- Max. air inlet pressure,
- Max. working pressure,
- Max. temperature,
- Weight,
- Serial number



Please ensure that the data on the type plate matches the information on the machine card. In case of errors or a missing type plate, please inform us immediately.

8.2 Machine card

The machine card contains all important and safety-relevant data and information for the machine.

- precise designation and manufacturer's data
- technical data and limit values
- equipment and test confirmation
- procurement data
- machine identification (machine components and accessories supplied with article and spare parts numbers)

- ▶ a list of the supplied documentation.

8.3 QR code

The QR code is located on the cart and on the back of this operation manual and contains a link which will direct you to machine support for your device type on the **WIWA** website.

You can find further information for your device there, such as e.g. spare parts lists, repair instructions, etc.

- ▶ Scan the QR code using your mobile device (e.g. smartphone, tablet).

In order to decrypt the QR code, you will need a QR code reader. It can be obtained on the Internet as an App free of charge.

8.4 Emission sound pressure level in the workplace

Sound pressure level L_{pA} at 15 DS with 8 bar	81
Sound power level L_{WA}	89



Your project deserves it.

Headquarter and production

WIWA Wilhelm Wagner GmbH & Co. KG

Gewerbestraße 1–3
35633 Lahnau
Germany
Phone: +49 (0)6441 609-0
Fax: +49 (0)6441 609-2450
Email: info@wiwa.de
Website: www.wiwa.de

WIWA subsidiary USA

WIWA LLC – USA, Kanada, Lateinamerika

107 N. Main St.
P.O. Box 398, Alger, OH 45812
USA
Phone: +1-419-757-0141
Fax: +1-419-549-5173
Email: sales@wiwa.com
Website: www.wiwausa.com

QR-Code

www.wiwa.de